



Part No. ALL30145  
ALL30146

## Oil Coolers Flange Mount

Adding an oil cooler to a vehicle increases engine life and reduces engine operating temperature. Engine oil not only lubricates but also removes a large amount of heat from the engine. Top engine builders recommend and often require use of an oil cooler. Coolers have a 1/2" NPT female bung commonly used for connecting a temperature sending unit or similar accessories and have built in flanges for mounting to the deck underside of most dirt late models, modifieds or other vehicles that would benefit from use of an oil cooler.

Part No.	Description
ALL30146.....	Cooler With -10AN Fittings, 4" x 15" x 3-1/2" Tall For Most Wet Sump Systems
ALL30145.....	Cooler With -12AN Fittings, 8-3/4" x 15" x 3-1/2" Tall For Most Dry Sump Systems

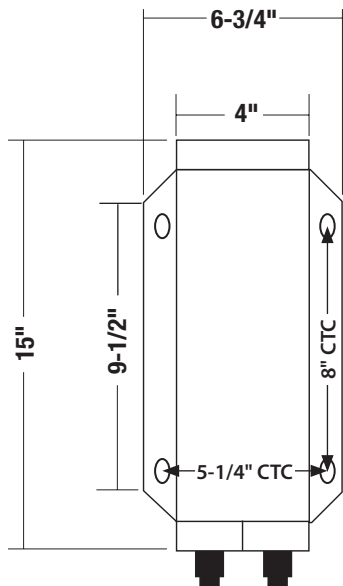
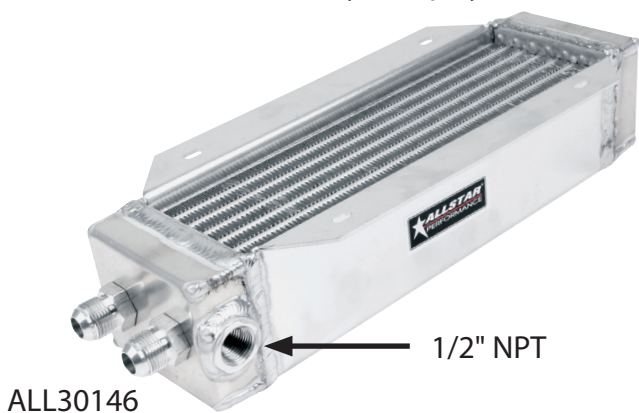

ALL30146

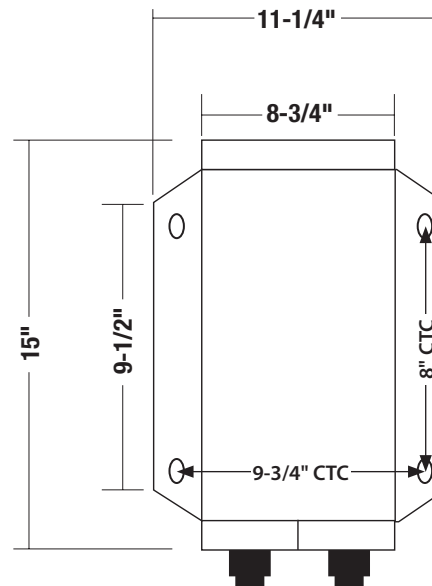

ALL30145

REV062315