



Part No. ALL68700-68824

Ford 9" Floater Axle Housings

Housings are jig welded for correct alignment using all new components including a fabricated center section, new 3" O.D. x 3/16" wall axle tubes and include a vent fitting, carrier mounting studs, fill and drain plugs. Note: Dimensions listed are from hub face to hub face.

Housing Width/Offset	2.0" Pin	2.5" Pin
58" / Centered	-	ALL68820
60" / Centered	ALL68700	ALL68822
62" / Centered	ALL68704	ALL68824
63" / 2" Offset	ALL68708	-



Tech Tip

Housing Measuring Diagram

Example: Bare housing ALL68708 is 63" from hub face to hub face and the pinion is located 2" to the left of the housing centerline when viewed from rear of housing.*

Please measure and inspect housing before welding brackets or painting. Housing is non-returnable if modified or custom. Welding suspension brackets on rear end housings can cause warping. These housings use Allstar ALL72100 inner grease seals.

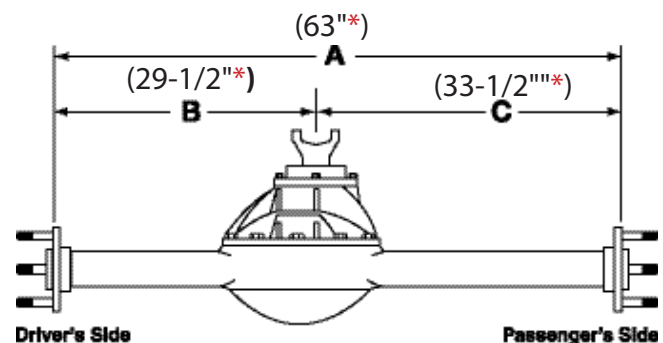

* Dimensions for example only.

REV052523